

Overview

StarCall cards and equipment provide flexible solutions for a wide range of applications. Its modular design allows you to easily build and configure a system that meets your requirements in a cost-effective manner, while leaving plenty of room for expansion and upgrades in the future.

Cards and Equipment

- Central Processor Card 2 (CPC2)
- Protected Balanced Telephone Card (BTC-P)
- Network Interface Card (NIC)
- Input Contact Card (ICC)
- Output Contact Card (OCC)
- Call Notification Telephone Card (CTC-2 and CTC-4)
- Administrative Telephone Card (ATC-E4)
- Standard Telephone Card (STC-E)
- Expanded Audio Switching Card (ASC-E)
- Trunk Interface Cards (TIC-E4 and TIC-E8)
- Central Office Cards (COC-4 and COC-8)
- Trunk Caller ID Module (TCM)
- Expansion Shelf
- Central Processor Card (CPC-E)
- Audio Routing Card (ARC-E)
- Basic Audio Switching Card (ASC-B)

StarCall Cards and Equipment

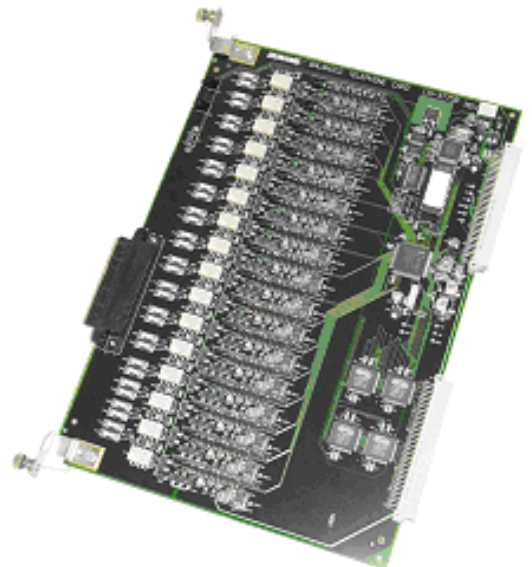

110-3763A Central Processor Card 2 (CPC2)

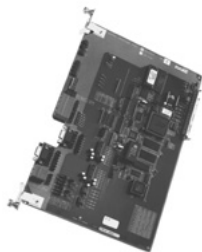

- Advanced multiprocessor design
- Modular feature package software
- Easy and secure servicing of feature packages
- Four external high-speed multipurpose communication ports
- System configuration and service by PC
- Remote access via modem
- 12 General purpose I/O ports
- Built-in user-programmable master clock
- Analog and digital clock correction
- Supports the RDU350 external wall display
- Supports networking of up to 16 StarCall plus systems
- Supports external PC monitoring and control

The GE Model 110-3763A Central Processor Card 2 (CPC2) is a second generation high-performance central control card for GE integrated communications systems. The CPC2 meets UL requirements and can be used in UL 1459 systems, which applies to the Model SCR Series.

The CPC2 manages all audio connections, data communications, and event processing using the resident system software. Data communications to other cards in the system occurs through a proprietary local operating network using the Echelon® LONWORKS® technology. Optional feature packages can be activated to add features to the base software. The CPC2 also contains the system configuration file that describes all cards and components in the integrated communications system, as well as all programmable system attributes.

Application

The CPC2 supports the following new card models, which the first generation Model 110-3521A Central Processor Card (CPC-E) cannot:

- Model 110-3823A Input Contact Card (ICC)
- Model 110-3824B Output Contact Card (OCC)
- Model 110-3851A Call Notification Telephone Card (CTC-2)
- Model 110-3852A Call Notification Telephone Card (CTC-4)
- Model 110-3889A Network Interface Card (NIC)
- Model 110-4001 Central Office Card (COC4)
- Model 110-4002 Central Office Card (COC8)
- Model 110-4003 Trunk Caller-ID Module (TCM)

Software feature packages are activated before delivery, if ordered at time of system purchase. Additional feature packages can be purchased any time after system installation. Activation only requires key codes obtained from GE Technical Services and the use of RAPID or MDS, v3.00 and later. The CPC2 includes a Feature Package Storage Unit that is transferable between CPC2s for easy

servicing. Currently available feature software packages are listed in Associated Software. See the latest revisions of the corresponding product data sheets for feature package details.

The CPC2 has a high speed RS-232 service port to allow configuration and service of a GE integrated communications system through a local PC or a remote PC via a modem. System software can be updated using the GE Remote Maintenance Utility (RMU) PC software application, v3.00 and later. Configuration file creation and modification, as well as system diagnostics, are performed using the GE Remote Programming and Diagnostics (RAPID) PC application, v3.00 and later. RMU and RAPID software applications require Microsoft® Windows® version 3.1 or higher. Service port operation selection options are either 9,600 or 57,600 baud.

A second high speed RS-232 serial port is available as an Open Architecture Interface (OAI). It is used to add external PC control and monitoring of system activity through a number of GE StarCall Plus and StarCare PC software applications, including the Event Subscription Manager (ESM).

The CPC2 has two high speed RS-485 serial ports that can be configured to communicate with one or more GE RDU350 Remote Display Units. When connected to an RDU350 display, the CPC2 transmits status messages associated with a specific telephone extension to the display at 9,600 baud.

The CPC2 also provides the 12 input/output ports listed below, on removable connectors, to monitor and/or control external devices:

- Two SPDT relay ports
- Two multifunction open collector driver outputs (can be configured for digital clock control)
- Four multifunction dry input contacts
- Four ports that can be individually configured as open collector output drivers or dry input contacts

The CPC2 also provides a built-in master clock for system timekeeping. When Master Clock Feature Package 1 is enabled, the system provides a master clock with the capability for 500 events, 16 schedules, and 32 multipurpose zones. This clock can function as a master (primary) or secondary and is capable of correcting both digital and analog secondary clocks.

The CPC2 can report system hardware and software information. When requested to do so by the RAPID or MDS software applications, the CPC2 checks the system and reports information back to RAPID. The CPC2 checks the shelf address, card type, and software revision of each card in the system, including the CPC2 itself. The central processor supports Electronic Revision and Map Control (ERMC), which is designed to read and display additional system card hardware information. ERMC requires RAPID, v3.00 and later. The RAPID software will display a card's hardware (assembly) revision and address map revision, for cards that support ERMC.

V4.00 or later of the CPC2 operating software supports the Model 110-3889A Network Interface Card, which allows up to 16 StarCall Plus Systems to be networked together. It requires that the system be configured using v4.00 or later of RAPID or MDS. This feature is only available for StarCall Plus Systems.

Specifications

Capacity	One RS-232 service port—9,600/57,600 baud One RS-232 multipurpose serial port—9,600/19,200/38,400/57,600/115,200 baud Two RS-485 multipurpose serial ports—9,600/19,200/38,400/57,600/115,200 baud Two SPDT relay ports Two multifunction open collector driver outputs Four multifunction dry input contacts Four multifunction input/output ports
Terminations	DB-9 female for RS-232 ports Four-pin removable screw terminal strip for RS-485 ports Nine-pin removable screw terminal strip for relay and output ports Nine-pin removable screw terminal strip for input and I/O ports
Board Dimensions	8.7 in (22.1 cm) by 12.7 in (32.3 cm)
Board Construction	FR-4 glass epoxy
Space Requirement	Single card cage slot

110-3823A Input Contact Card (ICC)

- 48 Input ports
- Single twisted pair per input
- Adds flexibility to programming capabilities

The GE Model 110-3823A Input Contact Card (ICC) allows the GE integrated communications system to interface with external equipment such as pushbuttons, door contacts, and ancillary equipment that provides dry contact output signaling. One ICC supports up to 48 dry switch input contacts—each on a twisted-pair wire. Input contacts may be isolated or ground referenced.

Application

Each input port can initiate different system actions and activate output ports on the Model 110-3824B Output Contact Card (OCC). OCC port action is available in different modes including on, off, duration, pulse, cycle, and toggle. Each input port also has an optional enable/disable period by hour, minute, and by day-of-week.

The ICC requires that the GE integrated communication system be equipped with a Model 110-3763A Central Processor Card (CPC2).

All field wiring terminates to a customer-provided distribution punch block. Each ICC includes two 15-foot (4.6 m) pigtail-to-connector cable assemblies for connection between the ICC's plug-in receptacle and the punch block. Each cable supports 24 input port pairs.

The ICC meets UL requirements and can be used in UL 1459 systems, which applies to the Model SCR Series.

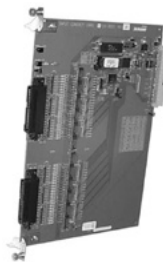

Specifications

Capacity	48 dry contact input ports
Input Response	Minimum contact closure time—125 milliseconds
Input Port Electrical Specifications	Open circuit voltage—24Vdc Maximum loop resistance including contact—15K Ohms Minimum sink capability of source—1.2 mA
Maximum Number of ICC Cards	Determined by system maximum port count—1,024 (sum of all ATC, STC, BTC, CTC, ASC, ICC, and OCC ports)
Termination	Customer-provided punch blocks Two 15-foot (4.6 m) pigtail-to-connector cable assemblies (AMP 229974-1 connector, 552011-1 cover)
Board Dimensions	8.7 in (22.1 cm) by 12.7 in (32.3 cm)
Board Construction	FR-4 glass epoxy
Space Requirement	Single card cage slot

110-3824B Output Contact Card (OCC)

- 48 Output ports—dry contact relay outputs, normally open
- Single twisted pair per output
- Adds flexibility to programming capabilities

The GE Model 110-3824B Output Contact Card (OCC) allows the GE integrated communications system to interface with external equipment such as closedcircuit TV (CCTV) video camera controllers, system status indicators, digital message units, and graphic control panels that accept dry contact signaling.

Application

One OCC supports up to 48 dry switch output contacts, each on a twisted-pair wire. Output contacts are individually jumper-selectable for normally open or normally closed relay contact operation, and are isolated from system ground. Each OCC output port can be activated in one of several modes including on, off, duration, pulse, cycle, and toggle.

Activation is triggered by any or all of the following, as configured in RAPID:

- Controlling system-timed events
- Controlling system activities for selected zones
- Speaker station ports, by specific action types
- Telephone ports, by specific action types
- ICC inputs—selected Input Contact Card ports

The OCC requires that the GE system be equipped with a Model 110-3763A Central Processor Card (CPC2) and programmed with version 3.00.

All field wiring terminates to a customer-provided distribution punch block. Each OCC includes two 15-foot (4.6 m) pigtail-to-connector cable assemblies for connection between the OCC's plug-in receptacle and the punch blocks. Each cable supports 24 output port pairs.

The OCC meets UL requirements and can be used in UL 1459 systems, which applies to the Model SCR Series.



Specifications

Capacity	48 dry contact output ports (individually selectable for normally open or normally closed operation)
Output Response	Minimum contact closure period—500 milliseconds
Output Port Electrical Specifications	Maximum load—1A @ 24V DC/AC Maximum voltage between output port contacts—100V Maximum voltage between output and GND—500V
Maximum Number of OCC Cards	Determined by system maximum port count—1,024 (sum of all ATC, STC, BTC, CTC, ASC, ICC, and OCC ports) Maximum per shelf—10
Termination	Customer-provided punch blocks Two 15-foot (4.6 m) pigtail-to-connector cable assemblies (AMP 229974-1 connector, 552011-1 cover) Two female receptacles on the ICC (AMP 552725-1)
Board Dimensions	8.7 in (22.1 cm) by 12.7 in (32.3 cm)
Board Construction	FR-4 glass epoxy
Space Requirement	Single card cage slot

110-3851A and 110-3852A Call Notification Telephone Card (CTC-2 and CTC-4)

- Provides two or four standard telephone ports
- Provides 32 global telephonic links
- Compatible with DTMF 2500 telephone set with electronic ringer or PBX central office loop start trunk port
- Supports telephones/PBX C.O. Trunk ports with caller id (cid) and caller ID on call waiting (CIDCW) capabilities
- Delivers calling party's room/extension number and call priority plus current time and date
- Telephones can be corded or cordless
- Includes additional circuit protection

The GE Model 110-3851A and 110-3852A Call Notification Telephone Cards (CTCs) provide service for up to four standard 2500 DTMF telephones with electronic ringers depending on the model. The 110-3851A provides service for two ports, and the 110-3852A provides service for four ports. Both models can alternatively configure any port to simulate a central office loop start trunk for connection to a PBX C.O. loop start trunk port.



Application

The CTC manages telephone access to the 32 global links available in the integrated communications system central equipment. In addition to standard telephone functionality, it delivers the current time and date, and the identity of the calling party through call notification, and supports Type I Caller ID (CID) or Type II Caller ID on Call Waiting (CIDCW) capable telephones and PBX C.O. trunk ports.

On-hook call notification data is delivered from the CTC port to on-hook telephone equipment between the first and the second ring signal on an incoming intercom call-in, telephone call, or trunk call. Data includes the calling party's numeric room/extension number, user configurable text to indicate call type and priority, and the current time and date. The system can be programmed to deliver a unique text string for each of the six intercom call-in priorities, and one for telephone calls. Each of these programmable text strings can also include the room/extension number. Trunk calls deliver a fixed text string but not the trunk line number. CID or CIDCW capable telephone equipment is required to receive the data. The method of displaying, storing, and using the call notification data is determined by the telephone equipment itself, not the CTC.

Off-hook call notification data is delivered from the CTC port to off-hook telephone equipment immediately after an incoming intercom call-in, if the call-in queue is empty, or if the new call-in is higher in priority than all other call-ins in the queue. CIDCW capable telephone equipment is required to receive the data. Off-hook call notification can be programmed to be disabled.

A Caller ID capable telephone can be corded or cordless for greater staff mobility. Telephones with multi-function keys can be used to view call-ins, access the system, and perform many of the functions available from the system Administrative Telephone (ATEL) at the touch of a button. Some of these functions are emergency paging, tone distribution, music distribution, and intercom.

Through the use of Caller ID capable C.O. loop start trunks ports on a PBX, room station call-ins and system telephone call extension numbers can be displayed on PBX administrative telephones. This integration allows the PBX administrative telephone to support identification of telephone and intercom calls from room telephones and speaker stations to the PBX.

Each CTC port can be individually configured to support either a telephone or PBX C.O. trunk port. Either configuration can support terminal equipment with or without Caller ID capability.

The CTC can be used in installations connected to exposed plant wiring such as portable buildings. The CTC includes additional circuitry to protect against dangerous voltages accidentally occurring on the exposed wiring. Additional circuit protection is also advisable in self-contained installations that experience frequent lightning exposure.

The CTC requires that the integrated communications system be equipped with a GE Model 110-3763A Central Processor Card (CPC2), loaded with system software version 3.04 or later.

Each telephone/PBX C.O. trunk port requires a single twisted pair. Maximum distance between a telephone or PBX C.O. trunk port and the CTC is 6,000 feet (1,829 m) using 22 AWG or 4,000 feet (1,219.5 m) using 24 AWG cable. All field wiring terminates to a distribution punch block provided by the customer. Each CTC includes a 15-foot (4.6 m) pigtail-to-connector cable assembly for connection between the CTC's plug-in receptacle and the punch block.

Specifications

Capacity	110-3851A—two ports 110-3852A—four ports 32 global telephone links
Terminations	Customer-provided punch block 15-foot (4.6 m) pigtail-to-connector cable assembly (AMP 229974-1 connector, 552011-1 cover) Female receptacle on CTC-2 (AMP 552725-1)
Board Dimensions	8.7 inches (22.1 cm) by 12.7 inches (32.3 cm)
Board Construction	FR-4 glass epoxy
Call Initiation	Off-hook or DTMF signaling (through system configuration programming)
Port Electrical Specifications	Line type: Balanced Loop current: 30mA On-hook voltage (TIP-RING): 18.5Vdc Switch-hook detect: 7mA to 13mA Ringing voltage: Provided by system, 90Vac 20Hz typical Ringing cadence: 1-1/2 seconds on, 4-1/2 seconds off Balance network (Balnet): 600 Ohms Input impedance Telephone configuration: 600 Ohms PBX C.O. trunk port configuration: 900 Ohms SAS signaling Frequency: 440Hz Level: -23dBm +/-2dBm power into 900 Ohms load CAS signaling Frequency: 2130Hz +2750Hz Level: -15dBm +/-1dBm power per tone into 900 Ohms load FSK (call notification data) Frequency: 1200Hz +2200Hz Level: -13.5dBm +/-1.5dBm power per tone into 900 Ohms load Over voltage protection: Meets UL 1459 for exposed plant wiring
Telephone Equipment Requirements	Telephone: DTMF 2500 set with electronic ringer PBX central office trunk port Line interface: Analog loop start Input impedance: 600 Ohms Balance network (Balnet): 900 Ohms Type I Caller compatible to support on-hook call notification Type II Caller compatible to support on-hook and off-hook call notification
Software Updates	Factory supplies pre-programmed EPROMs for main node Factory reprogramming for secondary node
Space Requirement	Single card cage slot

3889A Network Interface Card (NIC)

- Network up to 16 StarCall plus systems
- 16 Network voice channels
- Digital T1 interconnect for superior voice quality
- Provides 32 telephonic links within local system
- Network telephone operation
- Network intercom operation
- Network paging
- Network clock synchronization



The GE Model 110-3889A Network Interface Card (NIC) provides 16 digital inter-system voice channels, using T1 technology to interconnect StarCall Plus Systems.

Application

When two or more systems are connected together using NICs, these functions are available across the network:

- Telephone—the ability to dial, communicate, and forward calls from any Administrative Telephone (ATEL) or Standard Telephone (STEL) to any other ATEL or STEL in the networked system. Multiple, simultaneous telephone conversations are supported, subject to network and system resources and priorities.
- Intercom—the ability to dial and communicate from any ATEL or STEL to any room speaker in the networked system. Multiple, simultaneous intercoms are supported, subject to network and system resources and priorities.
- Call-in—the ability to configure call destination groups so that a call-in from any room station can be directed to any ATEL or STEL in the networked system.
- Paging—the ability to make a normal or emergency all call or zone page from any ATEL or STEL to any room speakers in the networked system. Multiple, simultaneous pages are supported, subject to network and system resources and priorities.
- Clock synchronization—the ability to synchronize the system clock (time and date) on secondary systems to the system clock on the primary system.

Up to 16 systems can be networked together with one NIC per system. One system is configured as the primary, while all others are secondaries. Each NIC supports 16 voice channels that can be used for telephone, intercom or paging, and one data channel for network signaling and control.

The systems are interconnected by a customer-provided, single pair, shielded T1 cable, Belden 7837A or equivalent, in a ring topology. One cable run is required for every system in the network, with each system transmitting to the next system in the ring so that one system's transmit becomes the next system's receive. The cable length can be up to 625 feet (190 m). For systems more than 625 feet apart, a T1 repeater or pairs of T1 extenders must be used. The distance between a system and the T1 repeater/extender can be up to 640 feet (195 m).

The customer-supplied T1 cable terminates to the screw terminal side of a surfacemount RJ-48X jack, provided with each NIC. Also provided is a 15-foot (4.6 m) standard, two pair, shielded, T1 modular cable that plugs into the modular jack side of the RJ-48X jack on one end and the RJ-48C modular jack on the NIC. See the system connection diagram.

Specifications

Capacity	16 communication systems 16 network voice channels 1 network data channel 32 local telephone links (within each system)
Terminations	RJ-48C keyed 8-pin modular jack on NIC 15-foot (4.6 m) keyed 8-pin modular jack T1 cable assembly Surface-mount RJ-48X keyed 8-pin modular jack NIC side: modular jack Field wiring side: numbered screw terminals
Board Dimensions	8.7 in (22.1 cm) by 12.7 in (32.3 cm)
Board Construction	FR-4 glass epoxy
Space Requirement	Single card cage slot

110-3547A Expansion Shelf

- Self-contained power supply
- Two intercom amplifier module (IAM) slots
- Fourteen-card capacity

The GE Model 110-3547A Expansion Shelf increases the capacity of a rack-mounted integrated communications system. The expansion shelf has sufficient power for a full population of cards and up to eight administrative telephones (ATELs). Each expansion shelf provides 14 universal card slots. There are also two vacant positions in the top of the expansion shelf for additional Intercom Amplifier Modules (IAMs). The expansion shelf includes all the cables required to connect to a Model 110-3546A Primary Shelf.

Specifications

Terminations	One 4-pin LON® interface to primary shelf One 64-pin telephone link interface to primary shelf One 6-pin power supply interface to primary shelf One 18-pin audio interface to primary shelf One 2-pin music bus interface to primary shelf
Capacity	Fourteen universal card slots, two intercom amplifier module slots

110-3775B Balanced Protected Telephone Card (BTC-P)

- Sixteen standard telephone ports
- Provides thirty-two global telephonic links
- Compatible with DTMF 2500 telephone set with electronic ringer

The GE Model 3775B Expanded Protected Balanced Telephone Card (BTC-P) provides service for up to 16 standard 2500 DTMF telephones with electronic ringers.



Application

The BTC-P manages telephone access to the 32 global links available in the central equipment rack of the integrated communications system. The telephones can be corded or cordless.

Each telephone requires a single twisted pair. Maximum distance between a telephone and the BTC-P is 6,000 feet (1,828 m) using 22 AWG or 4,000 feet (1,219 m) using 24 AWG cable. All field wiring terminates to a distribution punch block provided by the customer. Each BTC-P includes a 15-foot (4.6 m) pigtail-to-connector cable assembly for connection between the BTC-P's plug-in receptacle and the punch block.

The BTC-P meets UL requirements and can be used in UL 1459 systems, which applies to the Model SCR Series.

Specifications

Capacity	16 telephone (or equivalent) ports 32 global telephone links
Terminations	Customer-provided punch block 15-foot (4.6 m) pigtail-to-connector cable assembly (AMP 229974-1 connector, 552011-1 cover) Female receptacle on BTC (AMP 552725-1)
Board Dimensions	8.7 in (22.1 cm) by 12.7 in (32.3 cm)
Board Construction	FR-4 glass epoxy
Call Initiation	Off-hook or DTMF signaling (through system configuration programming)
Audio Distribution	600 Ohms balanced
Space Requirement	Single card cage slot

110-3527A Administrative Telephone Card (ATC-E4)

- Four Administrative Telephone (ATEL) Ports
- Provides Thirty-Two Global Telephonic Links
- Provides Background Music to the Administrative Telephone (ATEL)

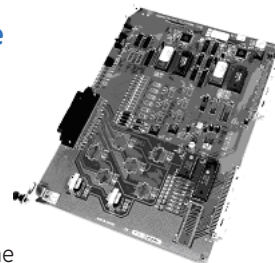

The GE Model 110-3527A Expanded Four-Port Administrative Telephone Card (ATC-E4) provides service for GE Model 7A1110 Administrative Telephones (ATELs) with displays. The ATC-E4 meets UL requirements and can be used in UL 1459 systems, which applies to the Model SCR Series.

Each ATEL connected to an ATC-E4 has access to one of 32 global telephone links in the central equipment, plus a background music bus. Field wires terminate to a customer-provided punch block. The ATC includes a 15-foot (4.6 m) pigtail-to-connector cable assembly for connection between the ATC's plug-in receptacle and the punch block.

Each ATEL requires three twisted-wire pair—one each for data, audio, and power.

The ATC cable assembly brings data and audio to the punch block. A separate pair of customer-provided wires brings DC power to the punch block from +24Vdc terminals on the shelf power supply.

The maximum distance for the communications line between an

ATEL and the central equipment is 1,000 feet (305 m) using 22 AWG cable, or 650 feet (198 m) using 24 AWG cable. The maximum distance for the power line is 1,000 feet (305 m) using 18 AWG cable.

Specifications

Capacity	Ports for four 7A1110 ATELS One background music bus Thirty-two global telephone links
Terminations	Customer-provided punch block 15-foot (4.6 m) pigtail-to-connector cable assembly (AMP 229974-1 connector, 552011-1 cover) Female receptacle on the ATC (AMP 552725-1)
Board Dimensions	8.7" (22.1 cm) by 12.7" (32.3 cm)
Board Construction	FR-4 glass epoxy
Audio Distribution	600 Ohms single ended (internally) 600 Ohms balanced (externally)
Data Communications To Atels	Local Operating Network (LON®)

Space Requirement	Single card cage slot
-------------------	-----------------------

110-3531A Standard Telephone Card (STC-E)

- Offers Sixteen Standard Telephone Ports
- Provides Thirty-Two Global Telephonic Links
- Compatible with DTMF 2500
- Telephone Set with Electronic Ringer

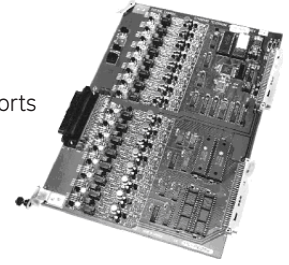

The GE Model 110-3531A (STC-E) Expanded Standard Telephone Card provides service for up to 16 standard 2500 DTMF telephones with electronic ringers and manages telephone access to the 32 global links available in the central equipment. The telephones can be corded or cordless. Each telephone requires a single shielded twisted pair. All field wiring terminates to a customer-provided distribution punch block.

Application

Maximum distance between a telephone and the STC is 3,000 feet

StarCall Plus Networking – System Connections

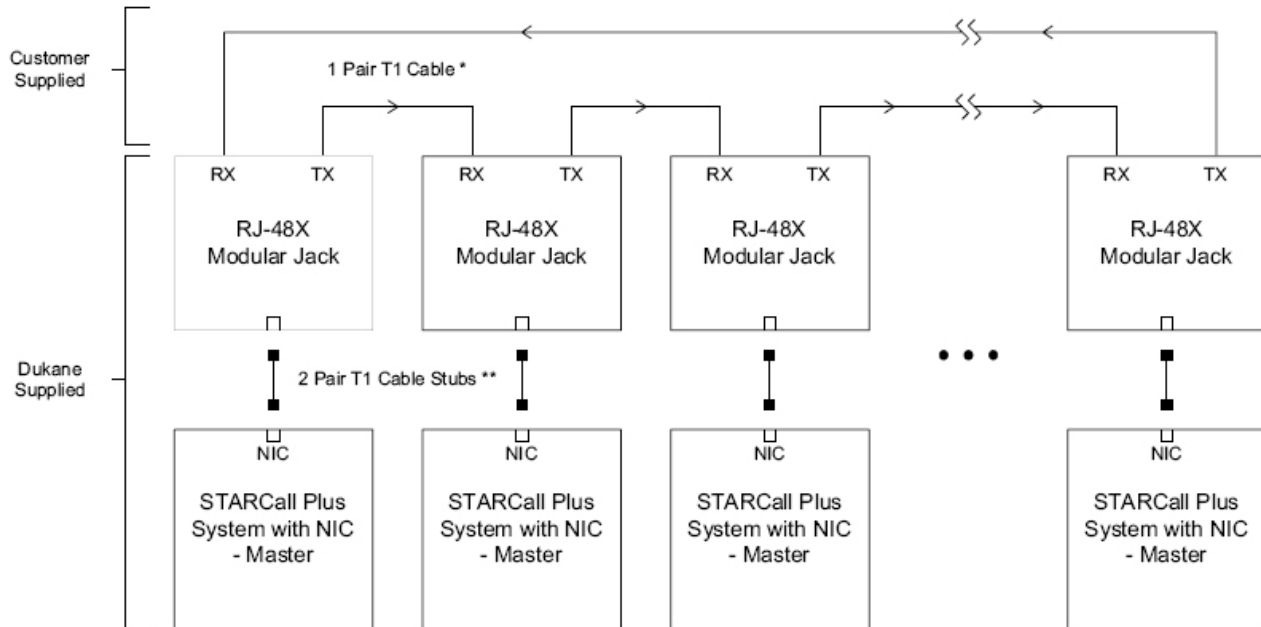

* 1 Pair Shielded T1 Cable, Belden 7837A or equivalent

Cable length between systems, including two 15 ft. (4.6m) stubs ≤ 655 ft. (200m)

** 15 ft. (4.6m) Modular Cable

(914 m) using 22 AWG wire or 2,000 feet (610 m) using 24 AWG. Each STC-E includes a 15-foot (4.6 m) pigtail-to-connector cable assembly for connecting the STC-E to the punch block. The STC-E meets UL requirements and can be used in UL 1069 central equipment and UL 1459 systems, both of which apply to the Model SCR Series.

Specifications

Capacity	16 telephone (or equivalent) ports 32 global telephone links
Terminations	Customer-provided punch block 15-foot (4.6 m) pigtail-to-connector cable assembly (AMP 229974-1 connector, 552011-1 cover) Connector receptacle on STC (AMP 552725-1)
Board Dimensions	8.7" (22.1 cm) by 12.7" (32.3 cm)
Board Construction	FR-4 glass epoxy
Call Initiation	Off-hook or DTMF signaling (through system configuration programming)
Audio Distribution	600 Ohms single ended
Space Requirement	Single card cage slot

110-3533B and 110-3534A Audio Switching Card (ASC-B and ASC-E)

- Sixteen Speaker Ports
- One or Two Multipurpose Audio Buses, Depending on Model
- Two or Six Audio Channels, Depending on Model
- Two Twisted-Pair Wires per Speaker with Call-In
- Supports up to Three Call-In Switches Plus Privacy and Call
- Assurance LED, Depending on Model
- Up to Seven User-Programmable Call-In Switch Priorities

GE offers two audio switching card models depending on system requirements. Both models connect up to sixteen 25-volt loudspeaker assemblies to the GE communications system central equipment rack. Two or six high-level audio channels, present on the back-plane, can be page, program, or intercom, as determined by the system configuration. Each ASC supports at least one call-in switch per speaker station. Each call-in switch provides a choice of seven user-programmable priorities. A normal call-in can be upgraded to an emergency call by rapidly pressing the call button twice. The maximum distance between an ASC and a remote speaker station is 4,000 feet (1,219 m) using 24 AWG or 6,000 feet (1,828 m) using 22 AWG.

Application

All field wiring terminates to a customer-provided distribution punch block. The field wiring from the switch/speaker combination to the punch block is two twisted pair with one shielded. Each ASC includes a 15-foot (4.6 m) pigtail-to-connector cable assembly for connection between the ASC's plug-in receptacle and the punch block.

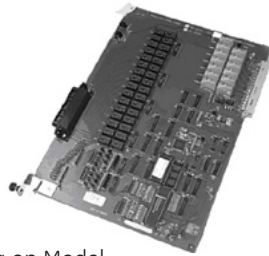

Model 110-3533B Basic Audio Switching Card (ASC-B)

The GE Model 110-3533B Basic Audio Switching Card (ASC-B) has one high-level audio bus that can select one of two high-level audio channels. The ASC-B supports one call-in switch per speaker station on a single twisted-pair 22 AWG annunciator cable. The ASC-B requires one GE Model 9A1765 Call-In Switch per speaker station. The ASC-B meets UL requirements and can be used in UL 1459 systems, which applies to the Model SCR Series.

Model 110-3534A Expanded Audio Switching Card (ASC-E)

The GE Model 110-3534A Expanded Audio Switching Card (ASC-E) has two high-level audio buses that can select two of six high-level audio channels. The ASC-E supports up to three call-in switches, privacy, and a call assurance LED per speaker station on a single twisted-pair 22 AWG annunciator cable. The ASC-E requires GE Model 9A4300, 9A4301, 9A4302 or, 9A4303 call-in switch stations. See Associated Equipment for product differences. The ASC-E meets UL requirements and can be used in UL 1459 systems, which applies to the Model SCR Series.

110-3551A and 110-3552B Trunk Interface Cards (TIC-E4 and TIC-E8)

- Four or Eight Trunk Ports, Depending on Model
- Provides 32 Global Telephonic Links
- Provides Selection of Delivery to Attendant or Direct System Dial Tone Access
- Provides Connection to KSU/PBX or Centrex

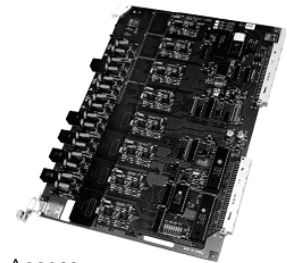

The GE Trunk Interface Card (TIC) provides connection to analog extension ports on a KSU or PBX. Two TIC models exist:

- Model 110-3551A (TIC-E4) has four ports and provides access to 32 global telephone links.
- Model 110-3552B (TIC-E8) has eight ports and provides access to 32 global telephone links.

Each TIC port can be configured to either return ring back to the calling party and route the incoming call to an attendant telephone or to return dial tone and provide direct inward DTMF dial access.

For outgoing calls, each of the 32 available TIC ports can be programmed to provide access by dialing an 80 through 89 and/or by dialing 9. If 9 is selected, each port can be programmed to automatically dial a second 9 for Public Switched Network access through a KSU or PBX.

Application

Line build-out jumpers allow configuration of each TIC port to optimize return loss. The TIC connects to standard telephone wiring using RJ-11 connectors. The TIC-E4 and TIC-E8 meet UL requirements and can be used in UL 1459 systems, which applies to the Model SCR Series.

Specifications

Capacity	110-3551A (TIC-E4): Four ports, 32 telephone links 110-3552B (TIC-E8): Eight ports, 32 telephone links
Terminations	RJ-11 modular jack on TIC
Board Dimensions	8.7" (22.1 cm) x 12.7" (32.3 cm)
Board Construction	FR-4 glass epoxy
Audio Distribution	600 Ohms balanced
Space Required	Single card shelf slot

110-4001 and 110-4002 Central Office Cards (COC-4 and COC-8)

- Four or Eight Trunk Ports, Depending on Model
- Supports Central Office Loop Start
- Loop Start E911 Compatible
- Incoming Only, Outgoing Only, or Two Way Operation
- Provides Selection of Incoming Calls to Hunt Group, DIL Extension, or Direct
- System Dial Tone Access
- Caller ID Capability Optional
- Supports Answer Supervision for Accurate SMDR Accounting
- Supports Auxiliary Connections to PBX or KSU Analog Extensions
- Selectable Balance Network

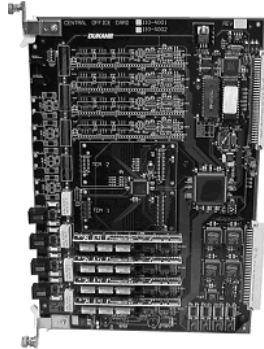

The GE Central Office Card (COC) provides for connection of a StarCall Fusion system to the Public Switched Network over Central Office Loop Start trunks. There are two COC models, the 110-4001 (COC-4) has four trunk ports and the 110-4002 (COC-8) has eight trunk ports. Each COC port can be configured as a Loop Start or Loop Start E911 trunk port.

When selected for Loop Start operation, the port can be programmed for incoming only, outgoing only, or two-way operation. For incoming operation, calls can be routed to a hunt group of extensions (select one from eight system hunt groups), a pre-programmed extension (Direct Inward Line), or receive a system dial tone. The system will support live or auto attendants. For outgoing operation, trunk ports can be accessed on a line group or selected line basis or both. Toll restriction can be programmed to be disabled on a per port basis if desired.

Application

When configured as a Loop Start E911 trunk port, the system will provide the necessary interface to support a compatible third party Enhanced 911 (E911) Emergency Service interface, which serves as a bridge to a local E911 network. Any system user dialing 911 will be routed directly through to the E911 network, complete with Automatic Number Identification (ANI) to aid in identifying the location of the caller within the building.

With the addition of the GE model 110-4003 Trunk Caller ID Module (TCM), the COC will support incoming caller ID. Each TCM supports four trunk ports and attaches directly to the COC. A COC-4 will support one TCM, applied to ports 1 to 4.

A COC-8 will support one or two TCMs, applied to ports 1 to 4 and/or ports 5 to 8.

Each port may be individually programmed to process or ignore incoming caller ID information.

Each COC trunk port can support both battery reversal and open loop disconnect signaling methods from the incoming line. The system supports Answer Supervision (using battery reversal) to indicate that the far end party has answered an outgoing call so that accurate per second SMDR recording can be achieved.

A COC port may also be connected to a PBX or KSU analog extension or any other loop start device for the purpose of integrating the system with other telephone systems or auxiliary telephone devices. The trunk port must be selected as Loop Start and can be configured as incoming, outgoing or both.

Digit 9 automatic repeat can be programmed when connected to a PBX to access outside lines through the PBX.

A selectable balanced network for each COC allows connection to central office trunks as well as PBX/KSU analog extension ports.

Each model provides access to all of the system's 32 global telephonic links. All ports support toll restriction and music-on-hold.

The COC requires that the GE integrated communication system be equipped with a GE Model 110-3763A Central Processor Card (CPC2), loaded with system software version 5.00 or later.

Specifications

Capacity	Model 110-4001 (COC-4): Four trunk ports, 32 telephone links Model 110-4002 (COC-8): Eight trunk ports, 32 telephone links
Terminations	RJ-11 modular jacks on COC Two 18-pin connectors for TCM Tip/Ring Two 32-pin connectors for TCM Control and Data
Board Dimensions	8.7" (22.1 cm) by 12.7" (32.3 cm)
Board Construction	FR-4 glass epoxy

Trunk Port Electrical Specifications

Trunk Type	Loop start
Ac Input Impedance	600 Ohms
Balance Network	AT&T compromise or 600 Ohms
Ringing Voltage	20Vrms to 130Vrms
Ringing Frequency	17Hz to 68Hz
Operating Loop Current	15mA to 90mA
Off-hook Dc Resistance	190 Ohms to 290 Ohms
Software Updates	Factory supplied pre-programmed EPROM
Space Requirement	Single card cage slot
Software	Model SW-4000:StarCall Fusion Server Software (optional)

110-4003 Trunk Caller ID Module (TCM)

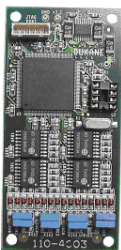

- Adds Caller ID Capability to Models 110-4001 COC-4 and 110-4002 COC-8
- Collects and Forwards Incoming Caller ID
- Supports Four Trunk Ports
- Compatible with Central Office Loop Start Trunks

The GE Model 110-4003 Trunk Caller ID Module (TCM) adds incoming Type I Caller ID receive capability from the Public Switched Network to the GE Central Office Card (COC).

Application

Each TCM provides caller ID service for up four trunk ports. A GE Model 110-4001 (COC-4) four port card supports one TCM, while Model 110-4002 (COC-8) eight port card supports one or two TCMs. A TCM attaches directly onto the COC-4 or COC-8. With the addition of a TCM, a COC will route incoming caller ID data to attendants, system extensions, as well as to one or more applications in GE model SW-4000 StarCall Fusion™ Server. For the COC-8 there are two locations for installation of a TCM, one for ports 1 to 4, the other for ports 5 to 8. When installing a single TCM, it may be placed in either location for use with either group of trunk ports. Each trunk port may be individually programmed to process or ignore incoming caller ID data. The TCM requires that the GE integrated communication system be equipped with a GE Model 110-3763A Central Processor Card (CPC2), loaded with system software version 5.00 or later.

Specifications

Capacity	Four trunk ports
Terminations	One 18-pin connector to COC for Tip/Ring One 32-pin connector to COC for Control and Data
Board Dimensions	1.75" (4.4 cm) by 3.65" (9.3 cm)
Board Construction	FR-4 glass epoxy
Electrical Specifications	Compatible with Bellcore GR-30-CORE 1200 baud Frequency Shift Keying (FSK) for Calling Name and Number reception
Software	Remote Programming and Diagnostics (RAPID) configuration software (version 5.00 or later) StarCall Fusion Server Software (optional)

Ordering Information

Model	Description
Expansion Shelf and Associated Equipment	
110-3547A	Expansion Shelf
110-3546A	Primary Shelf (required)
110-3527A	ATC-E4 Expanded Administrative Telephone Card (4 ports, 32 links)
110-3531A	STC-E Expanded Standard Telephone Card (16 ports, 32 links)
110-3533B	ASC-B Basic Audio Switching Card—StarCall only (16 stations, 1 path, 2 channels)
110-3534A	ASC-E Expanded Audio Switching Card (16 stations, 2 paths, 6 channels)
110-3544C	IAM Intercom Amplifier Module
110-3551A	TIC-E4 Expanded Trunk Interface Card (4 ports, 32 links)
110-3552B	TIC-E8 Expanded Trunk Interface Card (8 ports, 32 links)
110-3775B	BTC-P Protected Balanced Telephone Card (16 ports, 32 links)
Protected Balanced Telephone Card (BTC-P) and Associated Equipment	
110-3775B	Protected Balanced Telephone Card (BTC-P)
7A1111	Standard Telephone
110-3546A	Primary Card Shelf
110-3547A	Expansion Card Shelf
Network Interface Card (NIC) and Associated Equipment	
110-3889A	Network Interface Card (NIC)
110-3546A	Primary Card Shelf
110-3547A	Expansion Card Shelf
110-3763A	CPC2 Central Processor Card
Input Contact Card (ICC) and Associated Equipment	
110-3823A	Input Contact Card (ICC)
110-3546A	Primary Card Shelf
110-3547A	Expansion Card Shelf
110-3763A	Central Processor Card (CPC2)
110-3824B	Output Contact Card (OCC)
Output Contact Card (OCC) and Associated Equipment	
110-3824B	Output Contact Card (OCC)
110-3546A	Primary Card Shelf
110-3547A	Expansion Card Shelf
110-3763A	Central Processor Card (CPC2)
110-3823A	Input Contact Card (ICC)
Central Processor (CPC-E) and Associated Equipment	
110-3521A	Central Processor Card (CPC-E)
110-3524C	Audio Routing Card (ARC-E)
110-3546A	Primary Shelf
110-3547A	Expansion Shelf
77A1000	Modem Kit
437-00120A	Remote Programming and Diagnostics (RAPID) configuration software
437-00131A	Remote Maintenance Utility (RMU) application loading software

Central Processor Card 2 (CPC2) and Associated Equipment	
110-3763A	Central Processor Card 2 (CPC2)
110-3546A	Primary Shelf
110-3547A	Expansion Shelf
77A1000	Modem Kit
437-00120A	Remote Programming and Diagnostics (RAPID) configuration software
SW-2000	STARWare User Application Suite application software
110-3524C	Audio Routing Card (ARC-E)
437-00131A	Remote Maintenance Utility (RMU) application loading software
SW-4000	StarCall Fusion Server

Call Notification Telephone Card (CTC-2 and CTC-4) and Associated Equipment	
110-3851A & 110-3852A	Call Notification Telephone Card (CTC-2 and CTC-4)
110-3546A	Primary Card Shelf
110-3547A	Expansion Card Shelf
110-3763A	CPC2 Central Processor Card (version 3.04 or later)

Administrative Telephone Card (ATC-E4) and Associated Equipment	
110-3527A	Administrative Telephone Card (ATC-E4)
7A1110	Administrative Telephone
17A365	Power Supply (for additional Administrative Telephones)
110-3546A	Primary Card Shelf
110-3547A	Expansion Card Shelf

Standard Telephone Card (STC-E) and Associated Equipment	
110-3531A	Standard Telephone Card (STC-E)
7A1111	Standard Telephone
110-3546A	Primary Card Shelf
110-3547A	Expansion Card Shelf

Expanded Audio Switching Card (ASC-E) and Associated Equipment	
110-3534A	Expanded Audio Switching Card (ASC-E)
110-3546A	Primary Shelf
110-3547A	Expansion Shelf
9A4300	Call-In Switch with CALL, EMERGENCY, CANCEL, and PVCY (privacy) buttons and call assurance LED, two-gang
9A4301	Call-In Switch with CALL button and call assurance LED, single-gang
9A4302	Call-In Switch with CALL and CANCEL buttons and call assurance LED, single-gang
9A4303	Call-In Switch with CALL and PVCY (privacy) buttons and call assurance LED, single-gang

Trunk Interface Cards (TIC-E4 and TIC-E8) and Associated Equipment	
110-3551A	Trunk Interface Card (TIC-E4)
110-3552B	Trunk Interface Card (TIC-E8)
110-3546A	Primary Card Shelf (rack mount)
110-3547A	Expansion Card Shelf (rack mount)

Central Office Cards (COC-4 and COC-8) and Associated Equipment	
110-4001	Central Office Card (COC-4)
110-4002	Central Office Card (COC-8)
110-3546A	Primary Card Shelf
110-3547A	Expansion Card Shelf
110-3763A	CPC2 Central Processor Card (with software version 5.00 or later)
110-4003	TCM Trunk Caller ID Module

Trunk Caller ID Module (TCM) and Associated Equipment	
110-4003	Trunk Caller ID Module (TCM)
110-3546A	Primary Card Shelf
110-3547A	Expansion Card Shelf
110-3763A	CPC2 Central Processor Card (software version 5.00 or later)
110-4001	COC-4 Central Office Card, Four Ports
110-4002	COC-8 Central Office Card, Eight Ports

Central Processor Card (CPC-E) and Associated Equipment:	
110-3521A	Central Processor Card (CPC-E)
110-3524C	Audio Routing Card (ARC-E)
110-3546A	Primary Shelf
110-3547A	Expansion Shelf
77A1000	Modem Kit
437-00120A	Remote Programming and Diagnostics (RAPID) configuration software
437-00131A	Remote Maintenance Utility (RMU) application loading software

Audio Routing Card (ARC-E) and Associated Equipment:	
110-3521A	Central Processor Card (CPC-E)
110-3763A	Central Processor 2 Card (CPC2)
110-3546A	Primary Shelf
110-3547A	Expansion Shelf

Basic Audio Switching Card (ASC-B) and Associated Equipment:	
110-3533B	Basic Audio Switching Card (ASC-B)
110-3546A	Primary Shelf
110-3547A	Expansion Shelf
9A1765	Call-In Switch with PUSH TO CALL button, single gang
PCS499	Call-In Switch with CALL and PVCY (privacy) buttons, single gang

Primary and Expansion Shelf and Associated Equipment:	
110-3546A	Primary Shelf
110-3547A	Expansion Shelf
110-3542	Power Supply Module (PSM)
110-3543	Ringling Supply Module (RSM)
110-3544C	Intercom Amplifier Module (IAM)



U.S.
T 800-385-2639

Canada
T 519-748-5352
F 519-748-9221

www.gesecurity.com/sac

© 2007 General Electric Company
All Rights Reserved

StarCall and *StarCare* are trademarks of GE Security.
Echelon and *LONWORKS* are registered trademarks of
Echelon Corporation.
Microsoft and *Windows* are registered trademarks of
Microsoft Corporation.

