

ColorTouch VoIP Staff Console

HC-CONSOLE-E



The ColorTouch™ VoIP Staff Console is a primary point of contact among users of the Telligence™ patient-staff communications system. It operates as both a user interface and a communications device that sends and receives data and audio signals over the Telligence IP network.

As a user interface, the ColorTouch VoIP Staff Console graphically displays incoming calls from stations and connected healthcare equipment, and provides a means for the operator to prioritize and respond to selected events. As an audio device, it provides audible signaling functions and facilitates two-way full-duplex staff/patient and staff/staff communications. Enhanced audio helps to improve audio quality in noisy environments.

Passwords protect selected functions to restrict usage to approved users. Functions that can be restricted include Audio Page, Swing/Capture/Share and volume adjustments.

The ColorTouch VoIP Staff Console comes configured for desktop use. It includes a handset and cradle for privacy, or supports hands-free operation by means of its on-board full duplex speaker/microphone.

Features

- **14.2 cm (5.6 in) backlit ColorTouch screen display**
Easy to read and simple to configure with soft keys and customizable labels
- **VoIP and Powered Ethernet**
Category 5/5e/6 type wiring carries voice, data, and power on a single cable
- **Fully adjustable viewing angle**
Easy on the eyes under all lighting conditions
- **Unique tone associated with highest priority call**
Important incoming calls are identified uniquely
- **320 x 240 LCD resolution**
Bright high contrast display provides a clear picture
- **Full duplex speaker/microphone**
Hands-free communications for busy caregivers
- **One-touch call answer**
Simple operation helps ensure timely responses
- **RJ-45 connectivity**
Standard snap-in connectors help speed installation and maintenance
- **Multiple menu screens**
Concise information in a small footprint
- **Enhanced audio**
Helps to improve audio quality in noisy environments
- **Passwords protect selected functions**
Functions that can be restricted include Audio Page, Swing/Capture/Share and volume adjustments



Technical specifications

The ColorTouch VoIP Staff Console resides on the Telligence LAN/WAN and communicates with other IP devices over a single standard Category 5/5e/6 cable. This cable provides input and output for data and audio, as well as all necessary operating power for the device.

Assignment information relevant to each Staff Console may be stored locally in its on-board memory or centrally at the configuration server. The ColorTouch VoIP Staff Console is set up using Telligence configuration tools. This programming determines whether or not a call or system event will display at the ColorTouch VoIP Staff Console, and whether an audio connection should be established.

By subscribing to predetermined devices and events, the ColorTouch VoIP Staff Console can be set up to provide only the most relevant information at all times. Data is only sent to subscribed points, rather than being broadcast across the entire network. This powerful Telligence feature helps keep data flow down and communications speeds up.

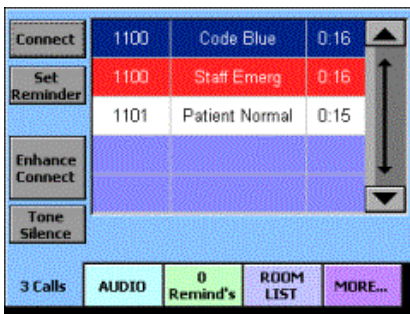

Installation

The ColorTouch VoIP Staff Console resides on the Telligence LAN as an IP device. It connects to the Telligence network with a Telligence PowerSwitch. Interconnection is by means of Category 5/5e/6 cable with RJ-45 connectors. Cabling carries data, audio, as well as all required operating power for the device.

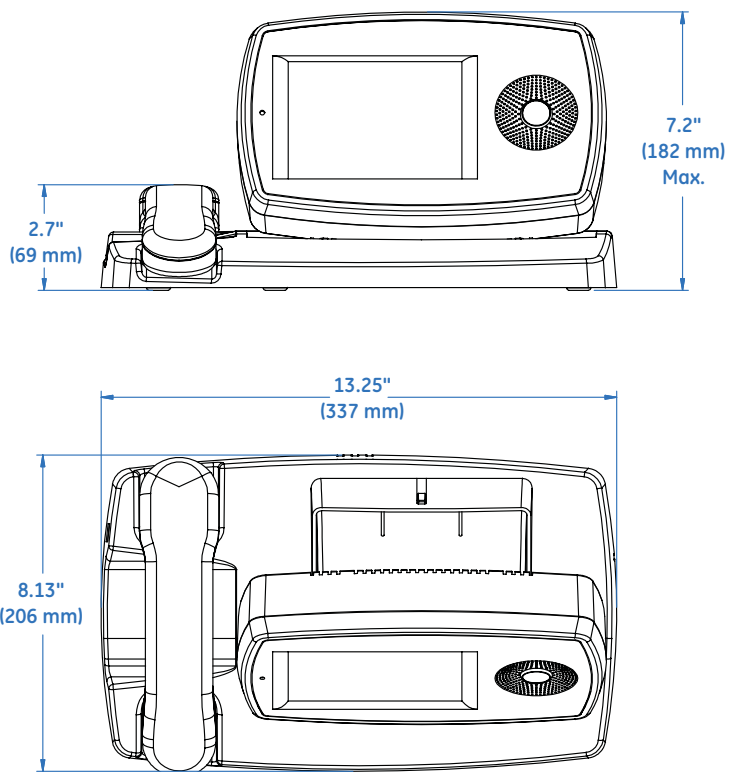
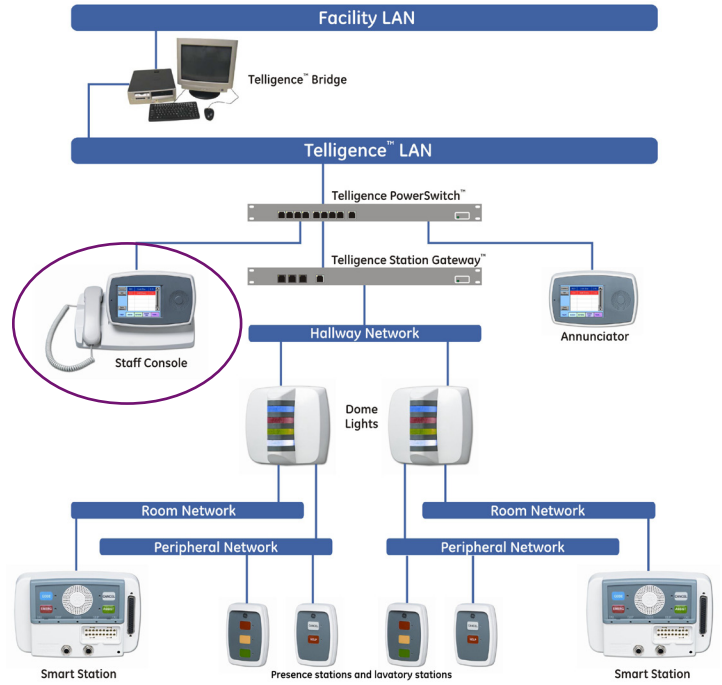

Performance specifications

Provide ColorTouch VoIP Staff Console(s) at the location(s) specified on the drawing. The equipment is a Voice over IP, desk mounted communication device with integral handset and color display. The housing features a 14.2 cm (5.6 in) backlit color touch screen display. The ColorTouch VoIP Staff Console is powered via the local area network connection and connects to the system using Cat 5/5e/6 cabling. The ColorTouch VoIP Staff Console provides complete full-duplex two-way Voice over IP and visible communications. The ColorTouch VoIP Staff Console is capable of serving a total of 512 Smart Patient and Staff/Duty Stations with a maximum of 8 beds per room.

The ColorTouch VoIP Staff Console is the primary control and monitoring point for voice communications and signaling functions. Users are capable of selecting full-duplex voice communication by means of the Staff Console's handset or hands free speakerphone.

The ColorTouch VoIP Staff Console provides a bright, easy-to read 14.2 cm (5.6 in) color touch screen display that provides at-a-glance visible indication of incoming calls, queued messages, and status indications. The ColorTouch VoIP Staff Console display provides an active call display showing location with priority and text message; individual call waiting messages showing the next call's location and priority; and the ability to scroll through the call queue.

The ColorTouch VoIP Staff Console provides a telephone dial pad screen for selecting individual stations, telephone dialing, and other numeric functions.

The ColorTouch VoIP Staff Console's default screen shows all active calls in order of priority. On screen UP/DOWN scroll arrows on the right side of the touchscreen allow the operator to view all calls from subscribed stations. Each call will indicate the room number, call type, and time elapsed since the call was made. Additional touch-screen buttons along the bottom of the display remain in view at all times.

Technical specifications

Audio output	Speaker/microphone for full duplex speakerphone mode or handset
Audio bandwidth	Approximately 64 kbps without compression

Power specifications

Electrical rating	40 VDC, 10.4 W
Power source	Powered Ethernet from PowerSwitch
Compatibility	Telligence patient-staff communication networks

Physical specifications

Dimensions (HxWxD)	33.7 x 20.6 x 18.2 cm (13.25 x 8.13 x 7.2 in)
Mounting	Desktop
Construction and finish	GE Cycoloy finished with a light texture to reduce fingerprints
Flammability rating	94 V-0
Terminations	RJ-45
Controls	Touch screen

Certifications

UL 1069, CSA (22.2 No. 205-M1983), FCC (Part 15, Class A)

GE Healthcare
8200 West Tower Avenue
Milwaukee, WI 53223
USA

www.gehealthcare.com



imagination at work

© 2009 General Electric Company – All rights reserved.

General Electric Company reserves the right to make changes in specifications and features shown herein, or discontinue the product described at any time without notice or obligation. Contact your GE Representative for the most current information.

Not to be used for installation purposes.

GE and GE Monogram are trademarks of General Electric Company.

Telligence, Telligence Station Gateway, Telligence PowerSwitch, BedConnect, DuraPin, ColorTouch and Infinity are trademarks of General Electric Company.

GE Medical Systems Information Technologies, Inc., a General Electric company, doing business as GE Healthcare.